



MVS1425B X-Band Magnetron

GENERAL DESCRIPTION

The MVS1425B is a fixed frequency pulsed type X-band magnetron designed to operate with a peak output power of 12.5 KW in the frequency range of follow:

MVS1425B 9380 to 9440 MHz

It is packaged and waveguide output type and forced or natural air cooled.

GENERAL CHARACTERISTICS

Electrical

Heater voltage (See note 1.)	6.3V
Heater current	0.55 A
Minimum preheat time (See note 2.)	60 sec. minimum

Mechanical

Dimensions	per outline drawing
Net weight	0.7 kg approximately
Mounting position	any
Cooling	forced air or natural
Output coupling	UG-40 B/U

MAXIMUM AND MINIMUM RATINGS (Absolute)

These ratings cannot necessarily be used simultaneously and no individual ratings should be exceeded.

	Min.	Max.	Units
Heater voltage (See note 1.)	5.7	6.9	V
Peak anode voltage	5.4	6.4	kV
Peak anode current	3.0	7.0	A
Mean anode power input (See note 3.)	---	70	W
Duty cycle	---	0.0025	
Pulse duration	---	2.5	μsec
Rate of rise of voltage pulse (See note 4.)	---	110	kV/μsec
Anode temperature	---	100	°C
V.S.W.R. at the output coupler	---	1.5:1	

TYPICAL OPERATION

Operational Conditions

Heater voltage	6.3 V
Peak Anode current	5.0 A
Pulse duration	1.0 μ s
Pulse repetition rate	1000 p.p.s
Duty cycle	0.001
Rate of rise of voltage pulse	70 kV/ μ s

Typical Performance

Peak anode voltage	5.8 kV
Peak output power	12.5 kW
Mean output power	12.5 W

TEST CONDITIONS AND LIMITS

The tube is tested to comply with the following electrical specification.

Test Conditions

Heater voltage (Operation)	6.3 V
Mean anode current	5.0 mA
Duty cycle	0.001
Pulse duration (See note 5.)	1.0 μ s
V.S.W.R. at the output coupler	1.1:1
Rate of rise of voltage pulse (See note 4.)	110 kV/ μ s

Limits	Min.	Max.	Units
Peak anode voltage	5.4	6.0	kV
Mean output power	10	---	W
Peak output power	10	---	kW
Frequency:	9380	9440	MHz
R.F. bandwidth at 1/4 power	---	2.5	MHz
Frequency pulling (v.s.w.r. not less than 1.5:1)	---	18	MHz
Stability (See note 6.)	---	0.05	%
Heater current			See note 7.
Temperature coefficient of frequency			See note 8.

LIFE TEST

End of Life Performance (under Test Conditions)

The tube is deemed to have reached end of life when it fails to satisfy the following.

Anode Voltage (Peak)	5.4 to 6.1 kV
Mean output power	9 W Min.
R.F. bandwidth at 1/4 power	3.5 MHz max.
Frequency:	9380 to 9440 MHz

NOTES

1. For all values of mean input power, no reduction of heater voltage is required and for optimum performance a value within the specified ratings must be maintained.
The magnetron heater must be protected against arcing by the use of a minimum capacitance of 4000 pF shunted across the heater directly at the input terminals, in some cases a capacitance as high as 2 μ F may be necessary depending on the equipment design.
2. For ambient temperatures above 0°C. For ambient temperatures between 0 and -55°C. Cathode preheating time is 90 seconds minimum.
3. The various parameters are related by the following formula:
$$P_i = i_b \times e_{py} \times D_u$$
where P_i = mean input power in watts
 i_b = peak anode current in amperes
 e_{py} = peak anode voltage in volts
and D_u = duty cycle
4. Defined as steepest tangent to the leading edge of the voltage pulse above 80% amplitude.
Any capacitance in the viewing system must not exceed 6.0PF.
5. Tolerance $\pm 10\%$
6. With the tube operating into a V.S.W.R. of 1.15:1 phase to give maximum instability.
Pulses are defined as missing when the r.f. energy level is less than 70% of the normal energy level in a 0.5% frequency range. Missing pulses are expressed as a percentage of the number of input pulses applied during the period of observation after a period of 10 minutes operation.
7. Measured with heater voltage of 6.3 V and no anode input power, the heater current limits are 0.5 A minimum, 0.6 A maximum.
8. Design test only. The maximum frequency change with anode temperature change (after warming) is -0.25 MHz/°C.

OUTLINE DRAWING

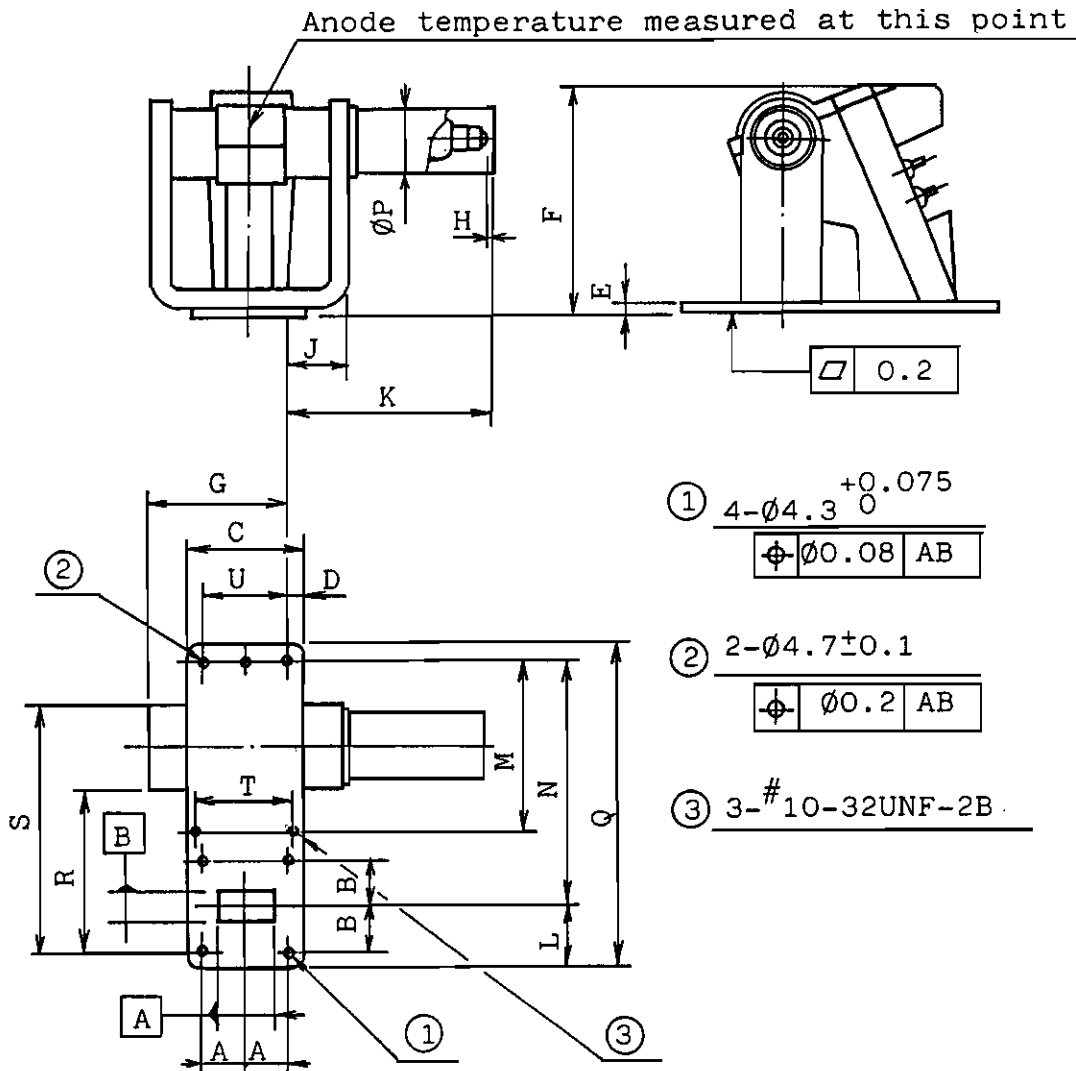

DIMENSION (UNIT : mm)

A : 15.5	B : 16.25	C : 41 ± 0.2
D : 5 ± 0.2	E : 3.0 ± 0.2	F : 84.2 max
G : 55.58 max	H : 3.18 max	J : 30.18 max
K : 74.6 ± 3.18	L : $20 \begin{matrix} +0.2 \\ -0.4 \end{matrix}$	M : 60.8 ± 0.2
N : 88	P : 25.4 max	Q : $113 \begin{matrix} +0.2 \\ -0.4 \end{matrix}$
R : 49.23 min	S : 101.6 max	T : 31.8
U : 31.0		

Bayonet Cap Connections

Contact	Element
End contact	Heater
Shell	Heater, Cathode